



Sealed Air

Shrink Packaging Division

Equipment Center

100 Westford Road

Ayer MA 01432 Telephone: (978) 487-2288

OPTI-SEAL 3000

Catalogo ricambi

(Valido dalla matricola nr. 249 del 02.2002)

Spare parts catalogue

(Valid from serial number 249 dated 02.2002)

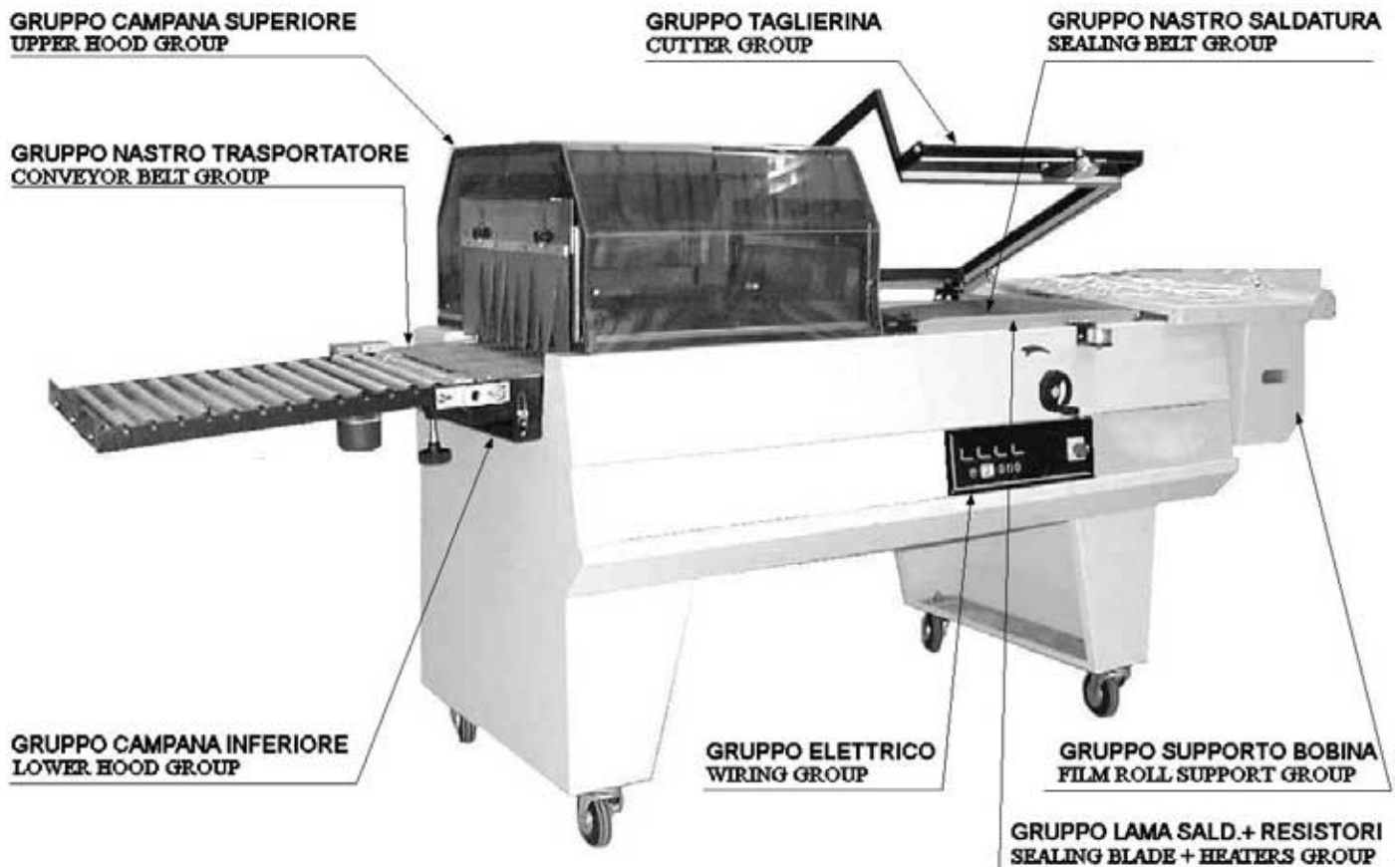

Consultare attentamente questo libretto prima di ordinare pezzi di ricambio
Carefully read this booklet before ordering spare parts



DOC. N. FM112039
REV. 01
Ed: 02.2002

УПАКОВОЧНОЕ ОБОРУДОВАНИЕ



ПРОИЗВОДСТВО И ПОСТАВКА
СЕРВИСНЫЙ РЕМОНТ
ЗАПАСНЫЕ ЧАСТИ
РАСХОДНЫЕ МАТЕРИАЛЫ

Диагностика, ремонт, сервисное обслуживание.

Запасные части и расходный материал: резина, тефлоновая лента, термонож (лезвие), гель для смазки.

Плѐнка термоусадочная полиолефиновая.

Система «Trade-In» – замена Вашего оборудования на новое и более производительное.



На фото: запайщик Magnetic FL900 + туннель Magnetic T100

ООО «АРДсистемы»

(495) 231-21-00

(812) 363-20-22

info@ardsystems.ru

www.filmtrade.ru

www.ardsystems.ru

INDICE GRUPPI DI RICAMBIO / INDEX OF SPARE PARTS GROUPS

TAVOLA NR. SCHEME N.	DESCRIZIONE DESCRIPTION	PAGINA PAGE
1	GRUPPO LAMA SALDANTE + RESISTORI SEALING BLADE + HEATERS GROUP	1
2	GRUPPO TAGLIERINA CUTTER GROUP	2
3	GRUPPO CAMPANA INFERIORE LOWER HOOD GROUP	3
4	GRUPPO CAMPANA SUPERIORE UPPER HOOD GROUP	4
5	GRUPPO SUPPORTO BOBINA FILM ROLL SUPPORT GROUP	5
6	GRUPPO NASTRO TRASPORTATORE CONVEYOR BELT GROUP	6
7	GRUPPO NASTRO SALDATURA SEALING BELT GROUP	7
8	GRUPPO AVVOLGITORE FILM (optional) FILM WINDER GROUP (optional)	8
9	GRUPPO ELETTRICO WIRING GROUP	9
	SCHEMA ELETTRICO WIRING DIAGRAM	10
	LEGENDA SCHEMA ELETTRICO WIRING DIAGRAM LEGEND	11

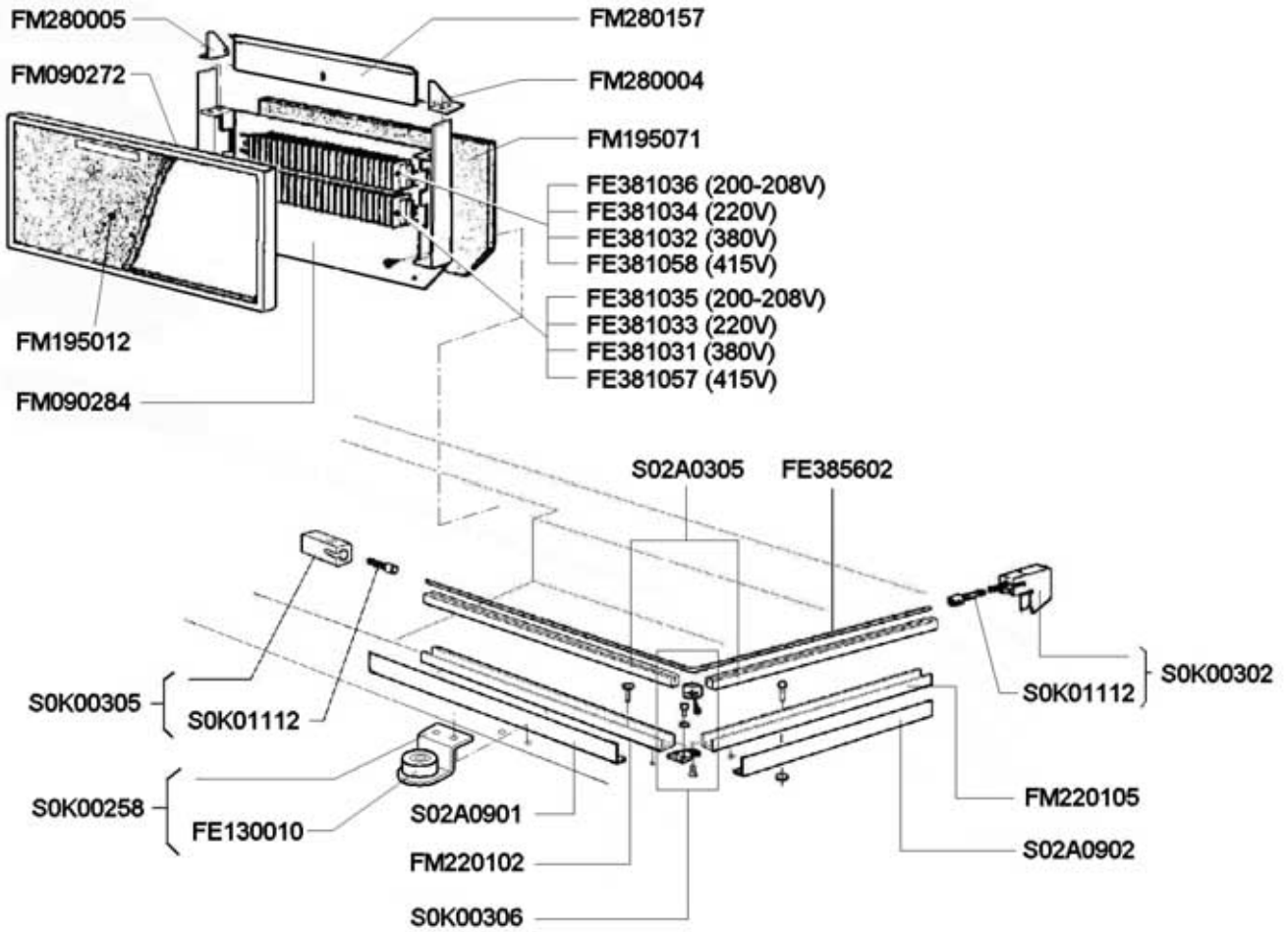

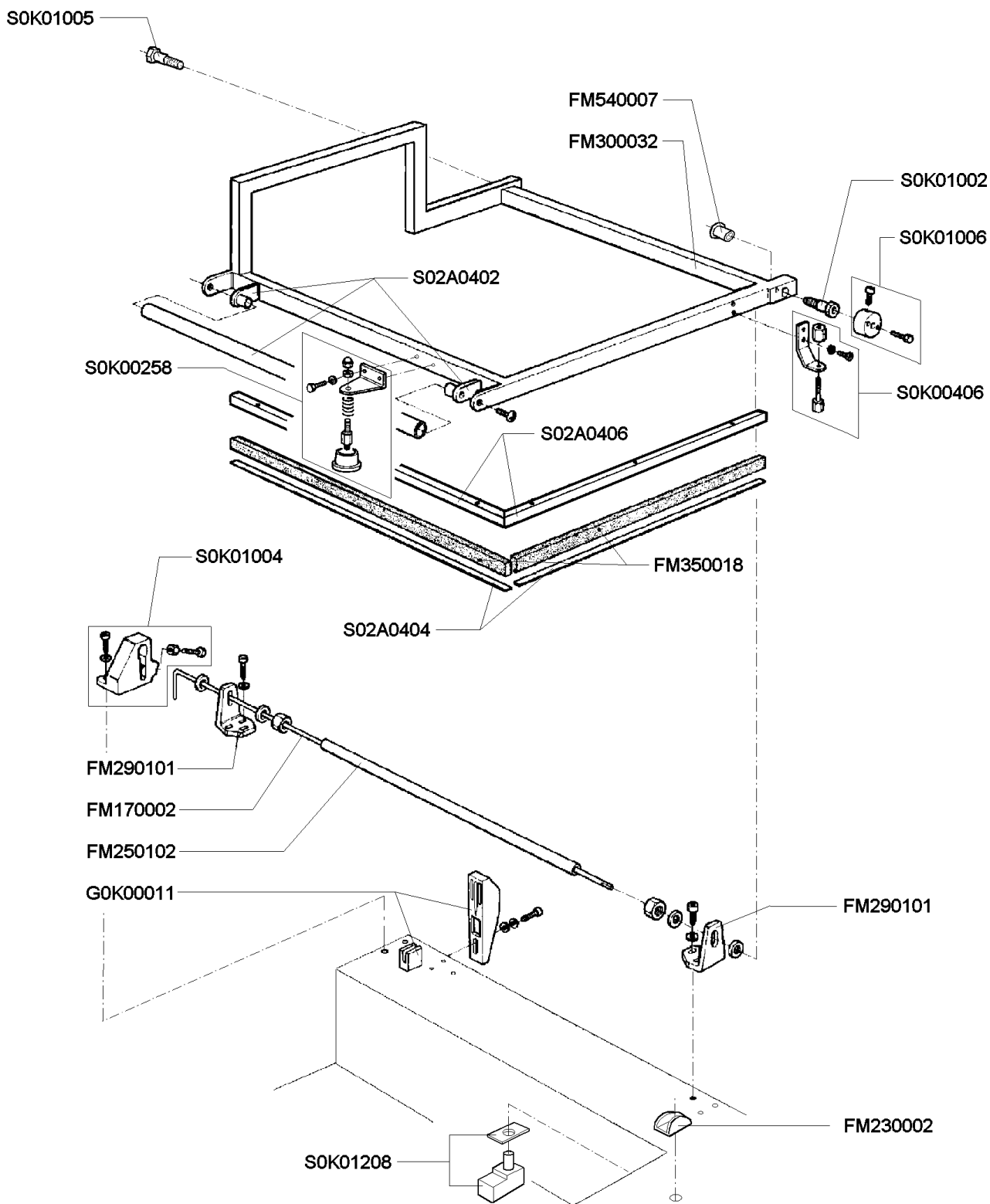

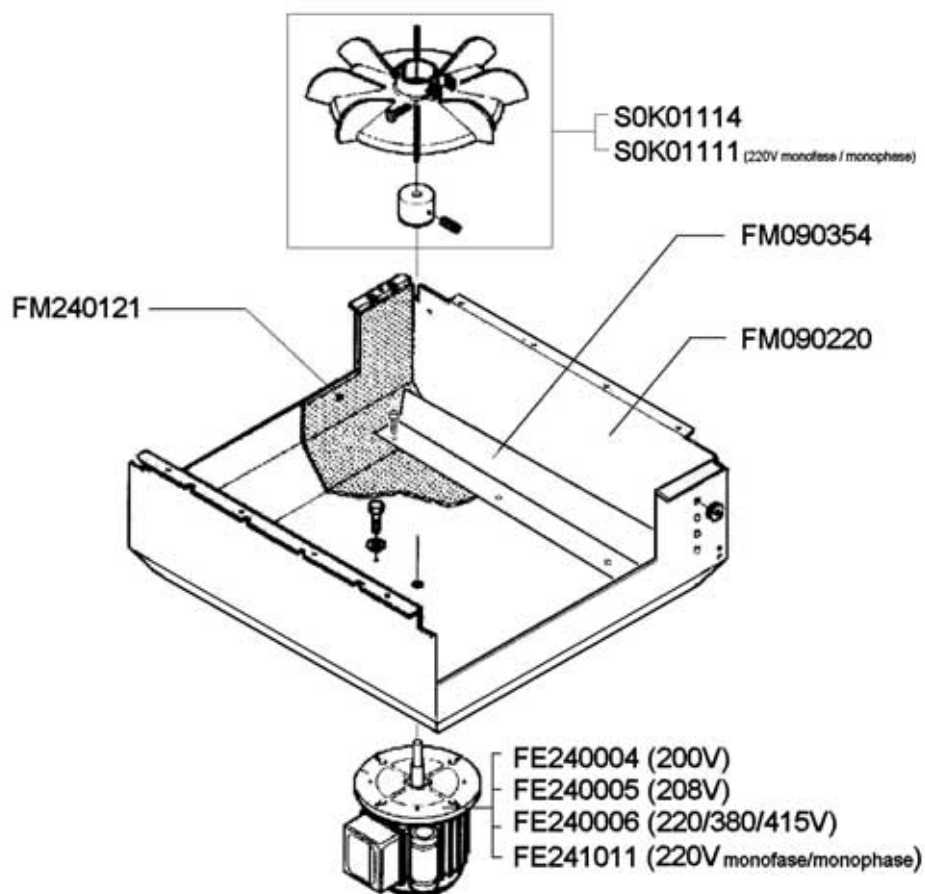

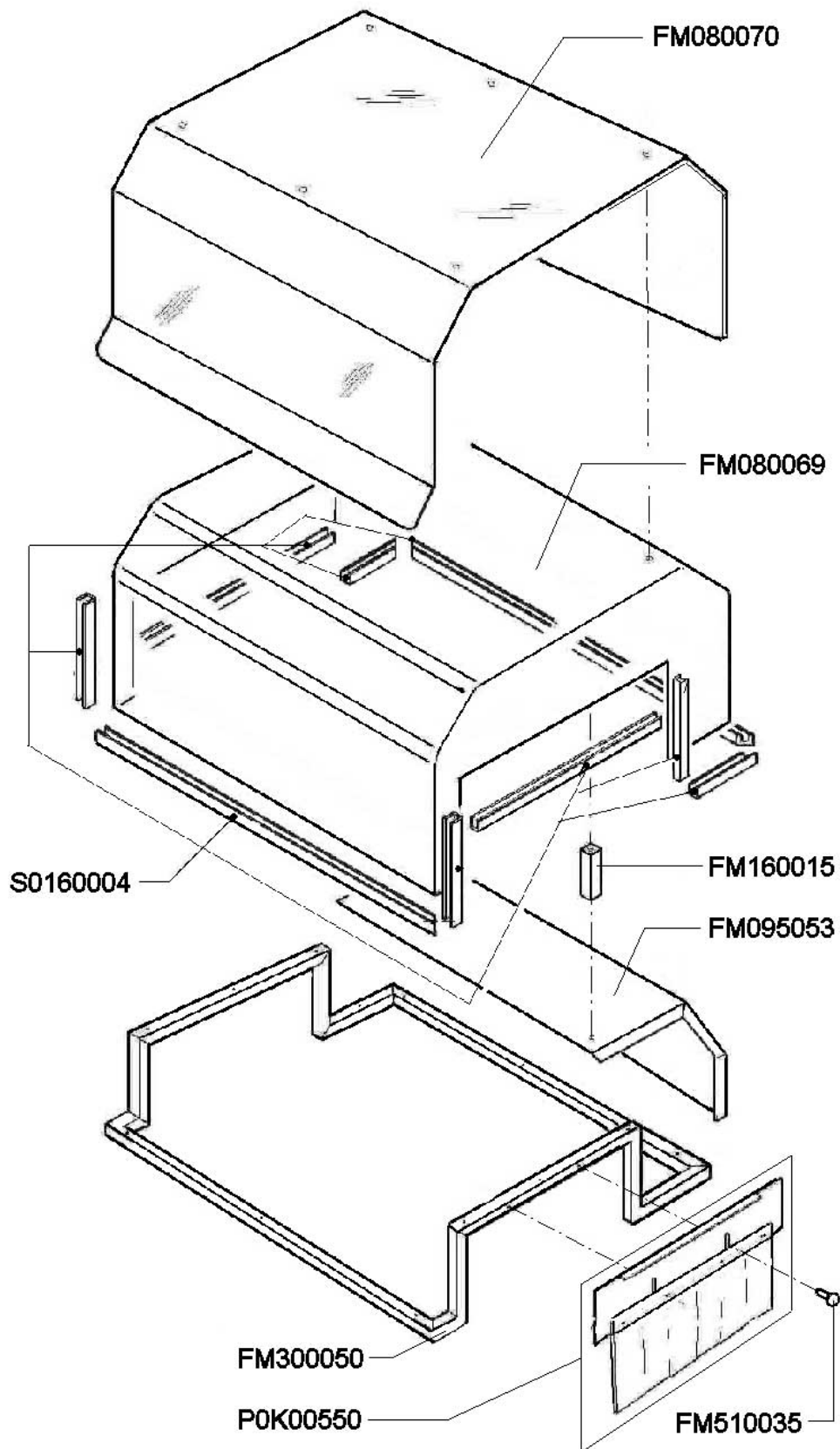

S0K00604

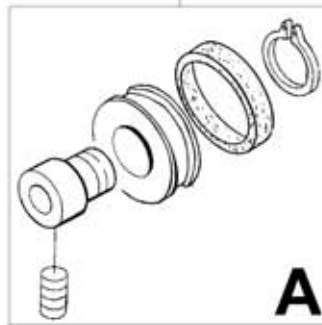

S0K00605

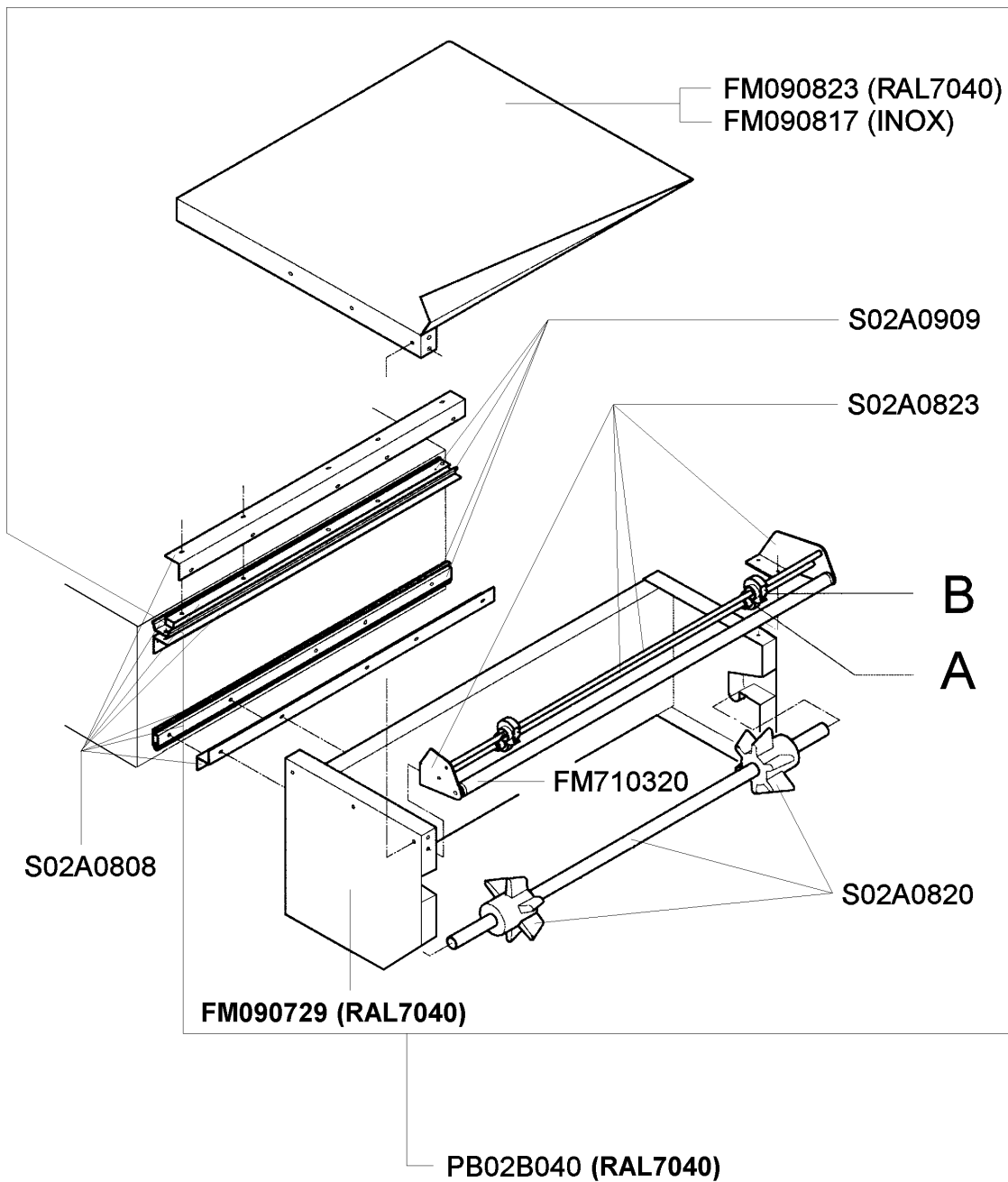
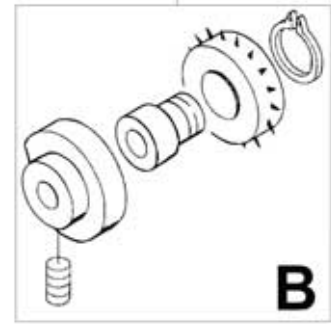

GRUPPO NASTRO TRASPORTATORE
CONVEYOR BELT GROUP

TAVOLA 6
SCHEME 6

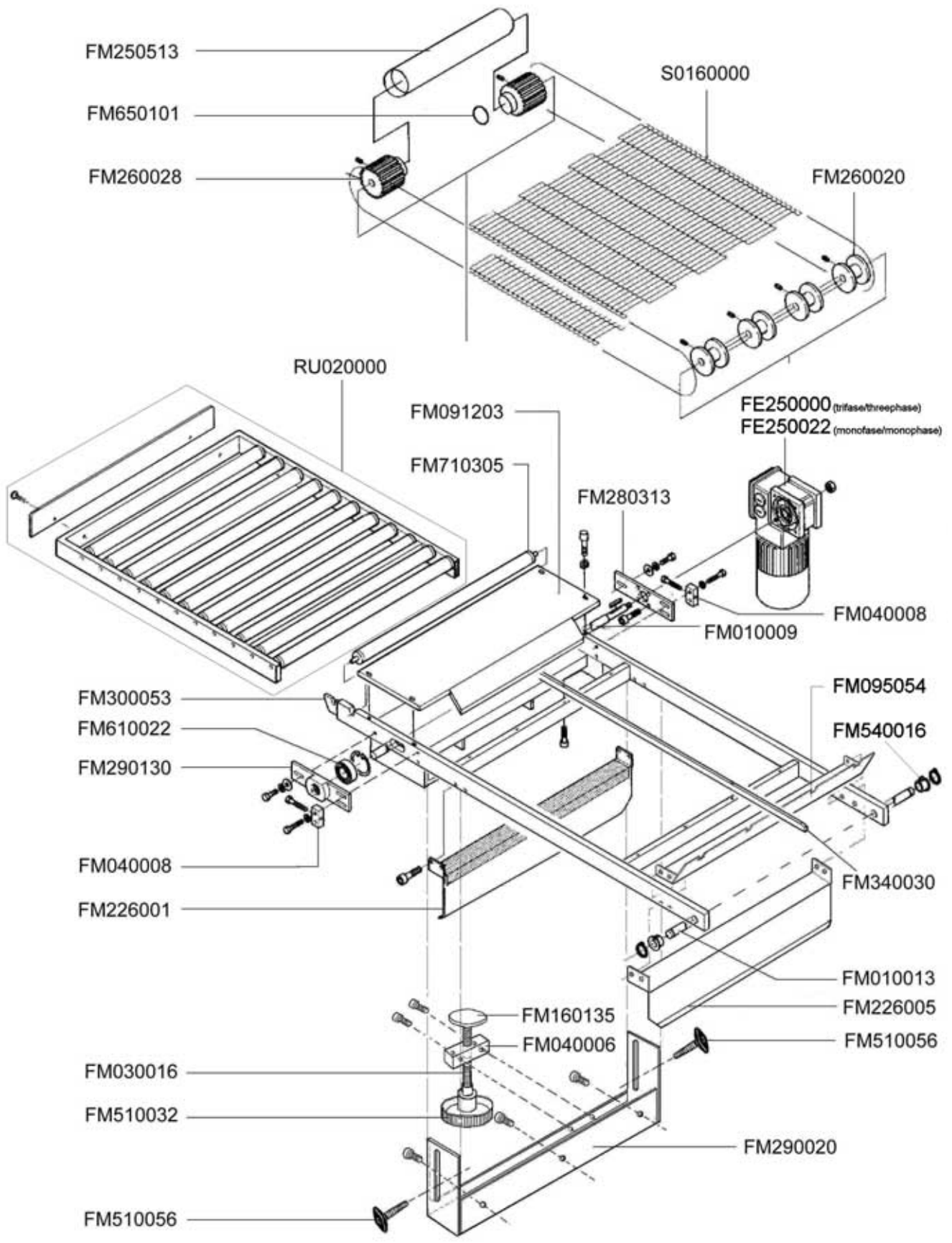

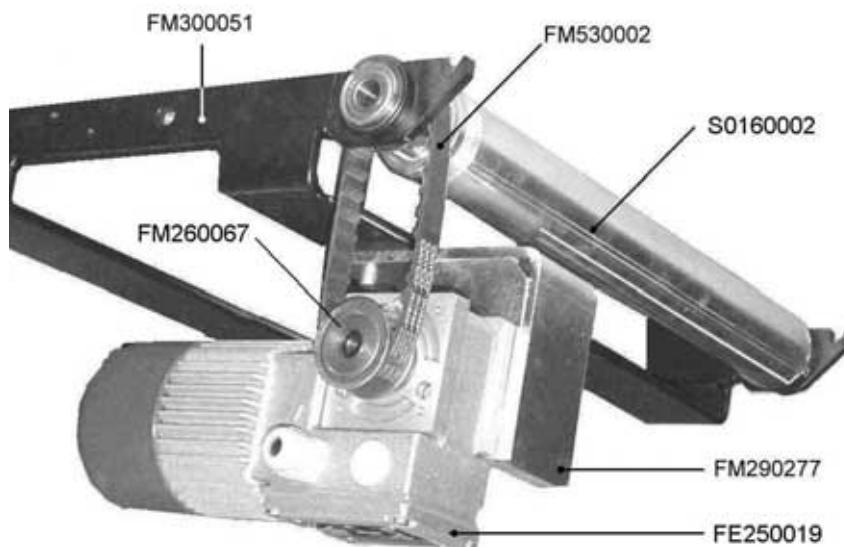

Lato ingresso / Inlet side

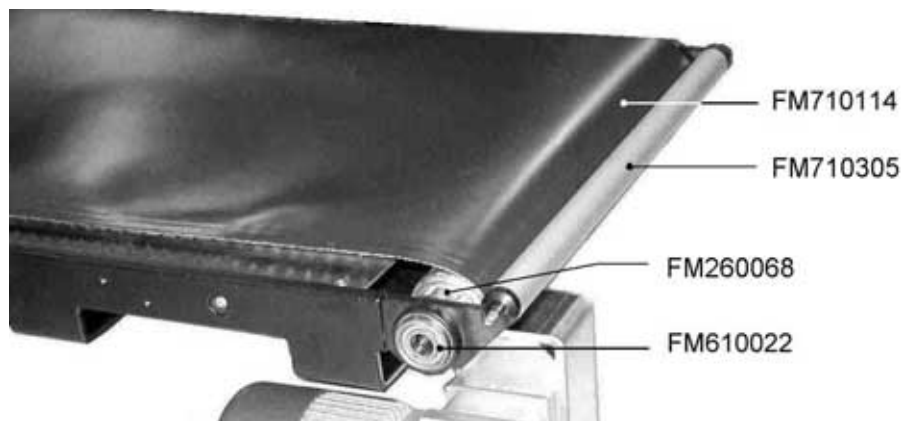

Lato ingresso / Inlet side

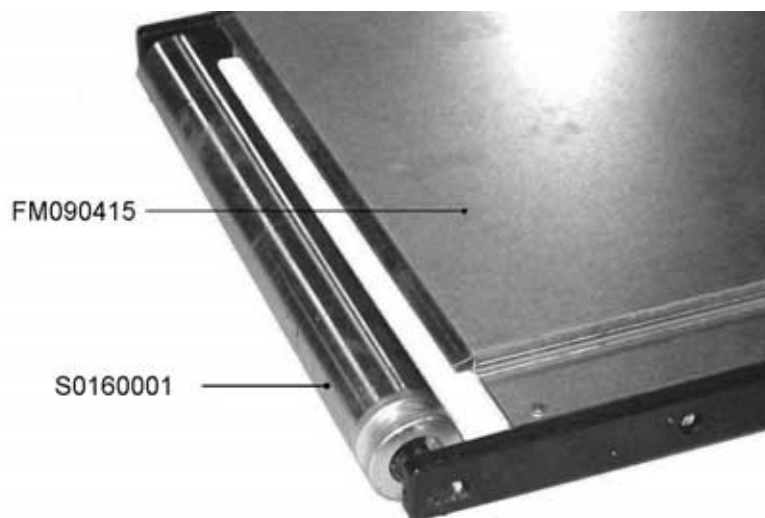

Lato uscita / Outlet side

GRUPPO AVVOLGITORE FILM (optional)
FILM WINDER GROUP (optional))

TAVOLA 8
SCHEME 8

AV160000

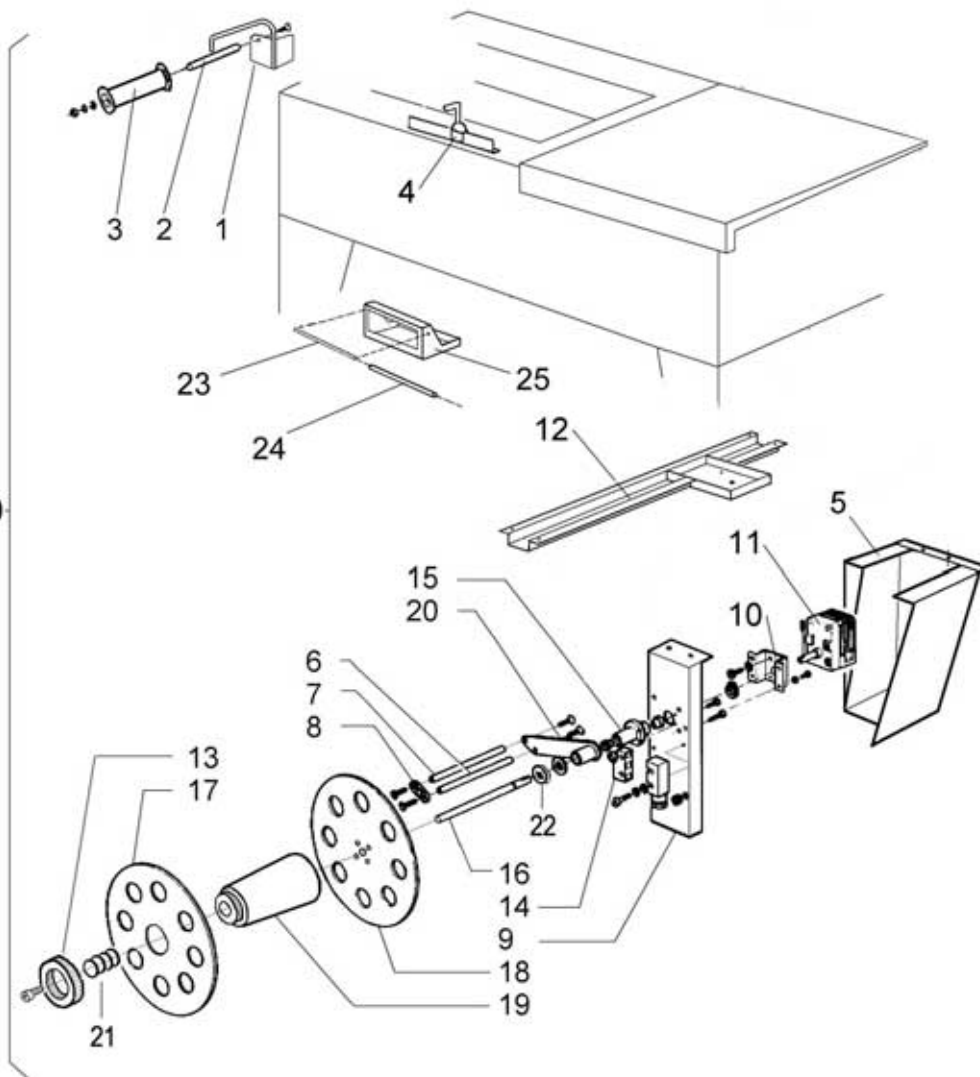

POS. POS.	CODICI PARTICOLARI ITEMS CODE	DENOMINAZIONI PARTICOLARI ITEMS DESCRIPTION	Q.tà Q.ty
1	FM290025	Supporto rinvio film / Film transmission support	1
2	FM200069	Perno per rullo di rinvio / Transmission roller pin	1
3	FM250049	Rullo rinvio / Transmission roller	1
4	S0K00407	Gruppo guida a piolo per film / Film roll guide group	1
5	FM095136	Carter motoriduttore / Gearmotor carter	1
6	FM030063	Asta per leva avvolgitore / Winder lever rod	2
7	FM250074	Rullo per avvolgitore / Winder roller	1
8	FM280326	Piastrina di collegamento / Connecting plate	1
9	FM290173	Supporto avvolgitore / Winder support	1
10	FM290107	Supporto motoriduttore / Gearmotor support	1
11	FE250016	Motoriduttore V220 / 220V gearmotor	1
12	FM290023	Traversa supporto avvolgitore / Winder support frame	1
13	FM160104	Ghiera di bloccaggio / Blocking ring nut	1
14	FE220105	Microinterruttore/ Microswitch	1
15	FM290172	Supporto leva tensore / Tightener lever support	1
16	FM010041	Albero per avvolgitore / Winder shaft	1
17	FM120022	Flangia mobile / Mobile flange	1
18	FM120015	Flangia fissa / Fix flange	1
19	FM250121	Mozzo / Hub	1
20	FM060027	Leva per avvolgitore / Winder lever	1
21	FM160086	Molla / Spring	1
22	FM160111	Rondella strisciamento avvolgitore / Winder Washer	1
23	FM200060	Perno per rullo di rinvio / Transmission roller pin	1
24	FM250038	Rullo rinvio / Transmission roller	1
25	FM290024	Supporto rinvio film / Film transmission support	1

GRUPPO ELETTRICO WIRING GROUP

TAVOLA 9 SCHEME 9

Pannello comandi /
Control panel

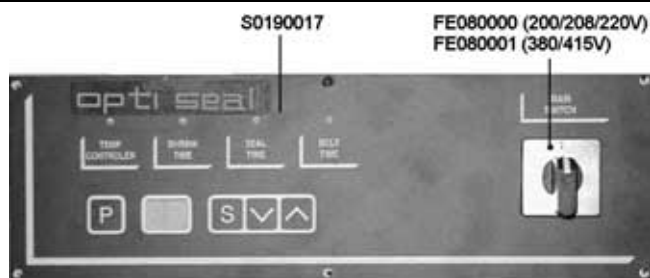

Cassetto elettrico trifase /
Threephase wiring box

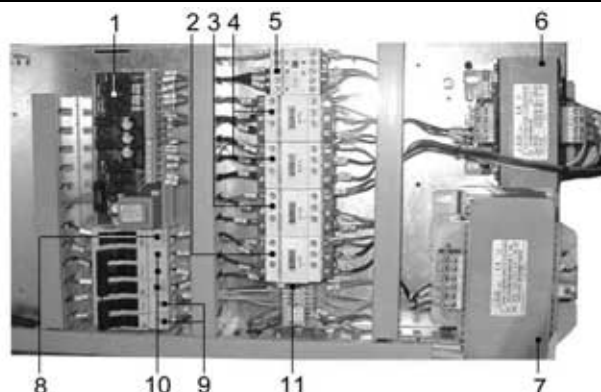

POS. POS.	CODICI PARTICOLARI ITEMS CODE	DENOMINAZIONI PARTICOLARI ITEMS DESCRIPTION	Q.tà Q.ty
1	FE120330	Modulo potenza / Power board	1
2	FE110615	Contattore LC1-D18B7 / Contactor LC1-D18B7	1
3	FE110602 (380/415V) FE110615 (200/208/220V)	Contattore LC1-D09B7 / Contactor LC1-D09B7 Contattore LC1-D18B7 / Contactor LC1-D18B7	1
4	FE110602	Contattore LC1-D09B7 / Contactor LC1-D09B7	2
5	FE110305	Contattore LP4-K0910BW3 / Contactor LP4-K0910BW3	1
6	FE440026 (380/415V) FE440025 (200/208/220V)	Trasformatore 400VA 380-415V / Transformer 400VA 380-415V Trasformatore 400VA 200-240V / Transformer 400VA 200-240V	1
7	FE440613 (380/415V) FE440612 (200/208/220V)	Trasformatore 2400VA 360-415V / Transformer 2400VA 360-415V Trasformatore 2400VA 200-240V / Transformer 2400VA 200-240V	1
8	FE290400 (380/415V) FE290401 (200/208/220V)	Fusibile CH10 10.3X38 1A / Fuse CH10 10.3X38 1A Fusibile CH10 10.3X38 2A / Fuse CH10 10.3X38 2A	1
9	FE290407 (380/415V) FE290408 (200/208/220V)	Fusibile CH10 10.3X38 16A / Fuse CH10 10.3X38 16A Fusibile CH10 10.3X38 20A / Fuse CH10 10.3X38 20A	2
10	FE290401 (380/415V) FE290402 (200/208/220V)	Fusibile CH10 10.3X38 2A / Fuse CH10 10.3X38 2A Fusibile CH10 10.3X38 4A / Fuse CH10 10.3X38 4A	3
11	FE290117	Fusibile 5X20 T1A / Fuse 5X20 T1A	1

Cassetto elettrico monofase /
Monophase wiring box

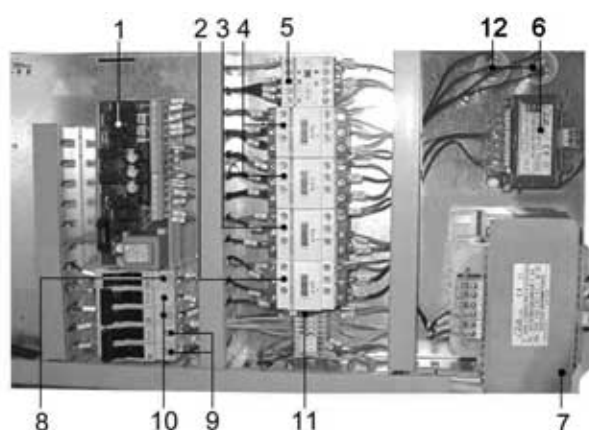

POS. POS.	CODICI PARTICOLARI ITEMS CODE	DENOMINAZIONI PARTICOLARI ITEMS DESCRIPTION	Q.tà Q.ty
1	FE120330	Modulo potenza / Power board	1
2	FE110615	Contattore LC1-D18B7 / Contactor LC1-D18B7	1
3	FE110615	Contattore LC1-D18B7 / Contactor LC1-D18B7	1
4	FE110602	Contattore LC1-D09B7 / Contactor LC1-D09B7	2
5	FE110305	Contattore LP4-K0910BW3 / Contactor LP4-K0910BW3	1
6	FE440015	Trasformatore 75VA 200-240V / Transformer 75VA 200-240V	1
7	FE440612	Trasformatore 2400VA 200-240V / Transformer 2400VA 200-240V	1
8	FE290410	Fusibile CH10 10.3X38 0,5A / Fuse CH10 10.3X38 0,5A	1
9	FE290408	Fusibile CH10 10.3X38 20A / Fuse CH10 10.3X38 20A	2
10	FE290402	Fusibile CH10 10.3X38 4A / Fuse CH10 10.3X38 4A	2
11	FE290117	Fusibile 5X20 T1A / Fuse 5X20 T1A	1
12	FE088001	Condensatore 8mf / Condenser 8mf	2

SCHEMA ELETTRICO WIRING DIAGRAM

Versione trifase / Threephase version

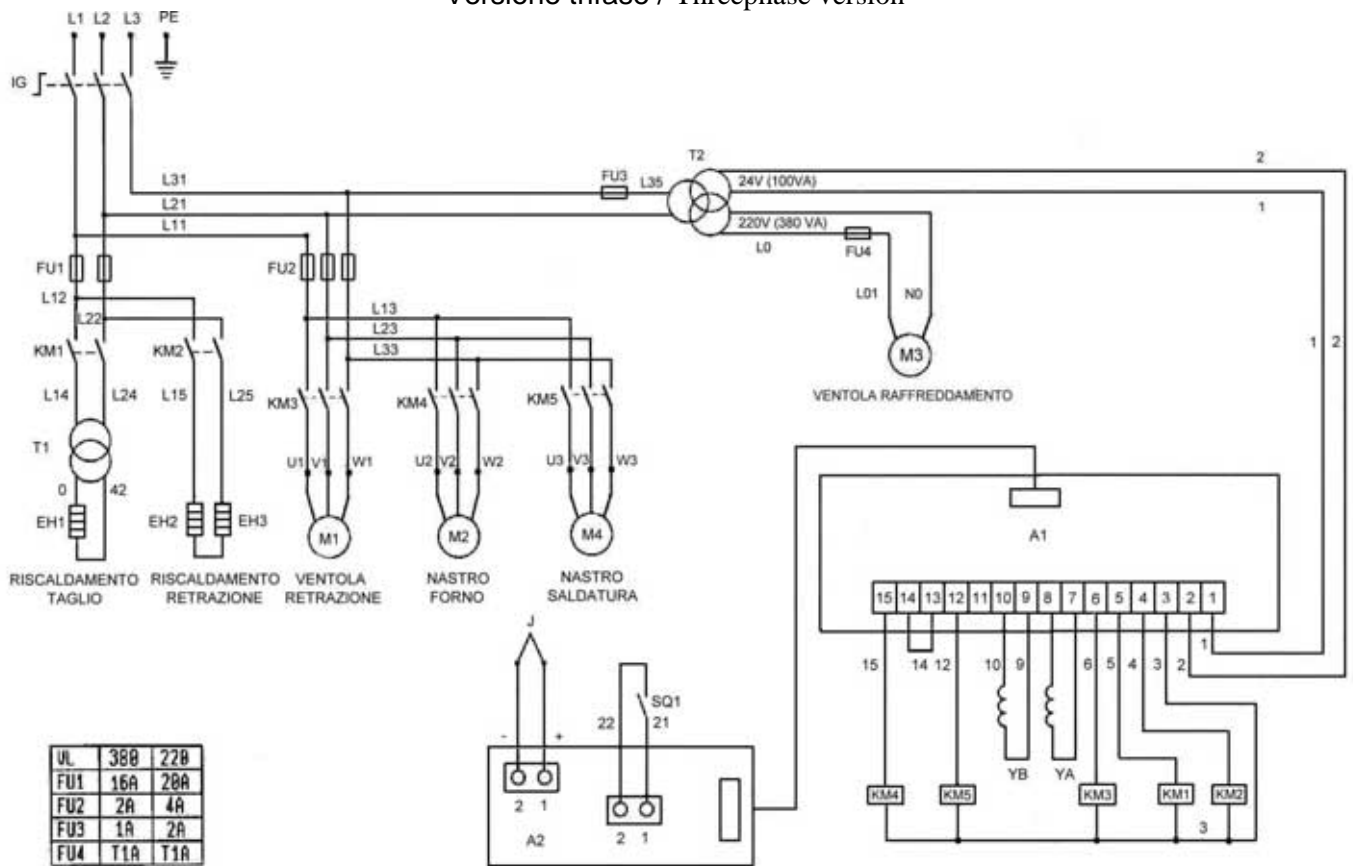

Versione monofase / Monophase version

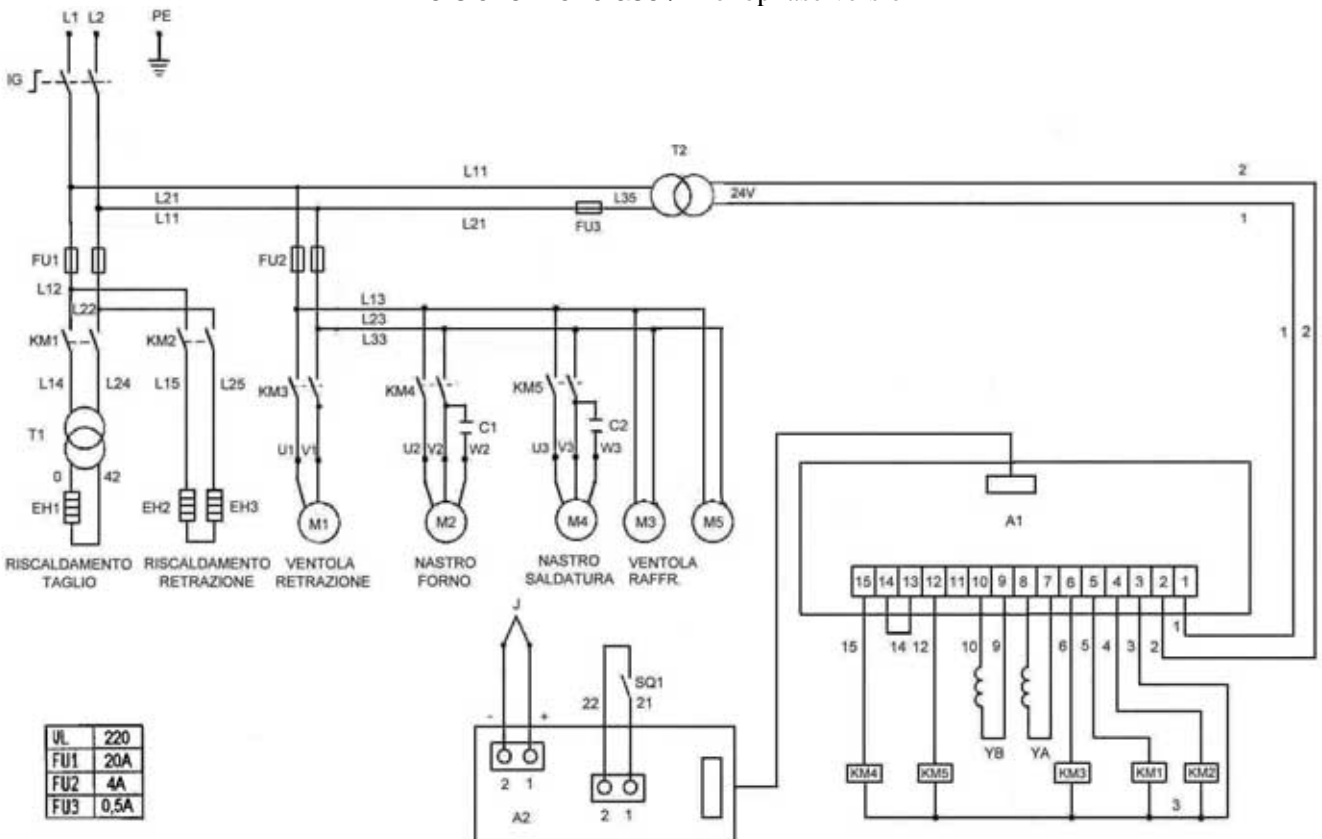

LEGENDA SCHEMA ELETTRICO WIRING DIAGRAM LEGEND

IG	Interruttore generale	A1	Modulo potenza
FU1	Fusibile generale Saldatura / Resistori	A2	Scheda comando
FU2	Fusibile nastri / Ventola retrazione	KM1	Contattore lama saldatura
FU3	Fusibile trasformatore ausiliario T1A	KM2	Contattore resistenze
FU4	Fusibile motore ventola T2A	KM3	Contattore motore ventola
EH1	Resistenza lama saldatura	KM4	Contattore motore nastro forno
EH2	Resistenza	KM5	Contattore motore nastro saldatura
EH3	Resistenza	M1	Motore ventola retrazione
T1	Trasformatore saldatura	M2	Motore nastro forno
T2	Trasformatore ausiliari	M3	Motore ventola raffreddamento
J	Termocoppia	M4	Motore nastro saldatura
SQ1	Micro start	M5	Motore ventola x motore retrazione
C1	Condensatore x motore nastro forno	YA	Elettromagnete retrazione
C2	Condensatore x motore nastro saldatura	YB	Elettromagnete saldatura
IG	Main switch	A1	Electronic control board
FU1	General fuse Cutting / Heater	A2	Control board
FU2	Oven tunnel / Shrinking fan fuse	KM1	Sealing blade contactor
FU3	Auxiliary transformer fuse T1A	KM2	Heaters contactor
FU4	Fan motor fuse T2A	KM3	Fan motor contactor
EH1	Sealing blade heater	KM4	Oven belt motor contactor
EH2	Heater	KM5	Motor contactor for sealing belt
EH3	Heater	M1	Shrinking fan motor
T1	Sealing transformer	M2	Oven belt motor
T2	Auxiliary transformer	M3	Fan motor of oven cooling
J	Thermocouple	M4	Sealing belt motor
SQ1	Machine cycle limit switch	M5	Fan motor of schrinking motor
C1	Condenser oven belt motor	YA	Shrinking magnet
C2	Motor condenser for sealing belt	YB	Sealing magnet